

BULETINUL INSTITUTULUI POLITEHNIC DIN IAȘI
Publicat de
Universitatea Tehnică „Gheorghe Asachi” din Iași
Tomul LIX (LXIII), Fasc. 2, 2013
Secția
CONSTRUCȚII. ARHITECTURĂ

SEISMIC DAMAGE EVALUATION OF AN RC DISSIPATIVE WALL

BY

SERGIU BĂETU^{1,*}, IOAN-PETRU CIONGRADI¹ and ALEX-HORIA BĂRBAT²

¹“Gheorghe Asachi” Technical University of Iași
Faculty of Civil Engineering and Building Services
²Technical University of Catalonia, Barcelona, Spain,
Department of Strength of Materials and Structural Engineering

Received: April 5, 2013

Accepted for publication: April 30, 2013

Abstract. An economic design of buildings based on performance criteria takes into account the dissipation of the seismic energy accumulated in the structure. In a tall structural wall, plastic hinges appear only at the base of the wall and the rest of the wall, which has not ductility resources, remains undamaged. A solution to increase the seismic performance of a reinforced concrete structural wall is to create a slit zone with short connections. Yielding of this shear connections increases the energy dissipation. The objective of these solutions is to create an improved structure for tall multi-storey buildings that has a rigid behaviour at low seismic action and turns into a ductile one in the case of a high intensity earthquake. In this paper, a comparative nonlinear dynamic analysis between slit walls and solid walls is performed by means of SAP2000 software and using a layer model. Our main objective is to evaluate the damage of slit walls in comparison with that of a solid wall.

Key words: slit wall; layer model; incremental dynamic analysis; energy dissipation; damage index.

*Corresponding author: *e-mail*: sergiubaetu@yahoo.com

1. Introduction

Reinforced concrete walls are structural elements used in multi-story buildings in earthquake prone countries like Romania, Turkey, Chile, Mexico, China, Japan, USA, Peru, etc., because they have a high capacity of resisting lateral loads. Nevertheless, such walls also require sufficient ductility to avoid brittle failure under the action of strong seismic loads. When a structure is subjected to strong earthquakes it is necessary to assure, for economical design reasons, inelastic deformations without the failure of the building; this is because the design of buildings based on performance criteria takes into account the dissipation of seismic energy accumulated in the structure. The fact is that, in a tall structural wall, plastic hinges appear only at the base of the wall and the rest of the wall remains undamaged. There is an alternative solution which overcomes this drawback, consisting of creating a slit zone with short connections introduced into the wall structure. The solution proposed in this paper – structural reinforced concrete slit walls – changes the behaviour of the solid wall and provides to the structure more ductility, energy dissipation and adequate crack patterns.

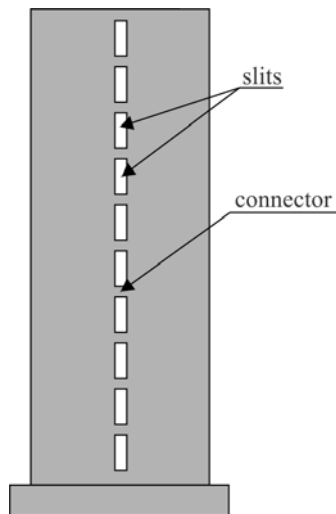

Fig. 1 – Cast-*in situ* slit wall with a slit zone with short connections (Kwan *et al.*, 1999).

The cast-*in situ* structural slit wall with a slit zone with short connections (Fig. 1) was proposed in China (Kwan *et al.*, 1999). This dissipative wall was studied by using nonlinear dynamic analyses considering the wall with a linear behaviour and the short connections with nonlinear behaviour. It was also numerically simulated with the column frame analogy.

Unlike the studies on slit walls of Kwan *et al.* (1999), which perform a dynamic analysis focused only on the nonlinear behaviour of the short connections, in the present paper we take into consideration the nonlinear behaviour of both the wall and the connections and our main objective is to evaluate numerically the damage of the slit wall in comparison with the damage of a solid wall.

2. The Computational Model

2.1. Material Definition

The characteristics of the concrete and steel used in the nonlinear dynamic analysis for modelling the reinforced concrete structural walls are discussed in this section. The concrete is the C32/40 one. For defining the layers of the confined and the unconfined concrete and of the steel, it is necessary to introduce their behaviour laws (Figs. 2 and 3) that describe the stress–strain relationships under cyclic behaviour (Martinez & Elnashai, 1997; Taucer *et al.*, 1991; Belmouden & Lestuzzi, 2007; Kwak & Kim, 2004; Nagarajan *et al.*, 2009; Sharifi *et al.*, 2012).

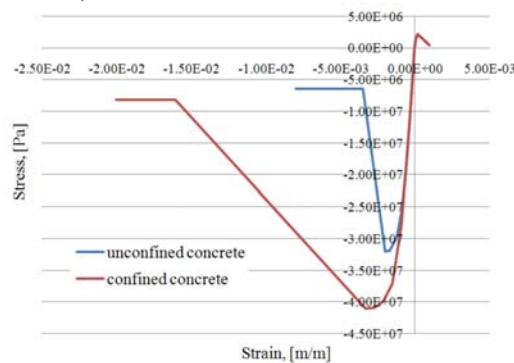

Fig. 2 – The behaviour law of confined and unconfined.

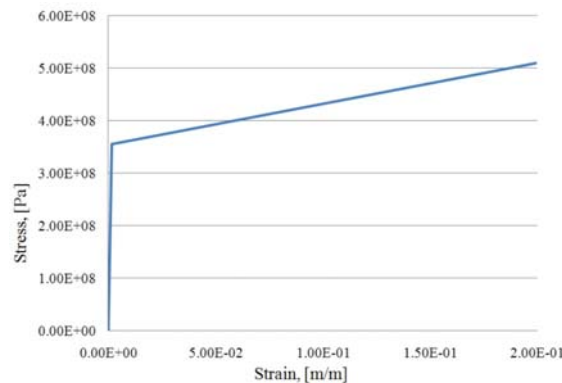

Fig. 3 – The behaviour law of steel.

The monotonic envelope curve of concrete follows the Takeda hysteretic model and the stress–strain curve of the steel follows the kinematic hysteretic model, both of them being predefined in SAP2000. The multilinear isotropic stress–strain curve for unconfined concrete is computed with the eqs. proposed by Desayi & Krishnan in 1964 (Kachlakev *et al.*, 2001) and, for confined concrete, the strength and deformations have been increased according to SR EN 1992-1-1:2004 (SR EN 1992-1-1:2004).

2.2. Description of the Layered Shell Element for the Structural Walls Analysis

The analysis of damage due to seismic actions requires the use of efficient structural models capable of describing the actual structural behaviour, like the layered shell model which is useful in performing nonlinear dynamic analyses of reinforced concrete structural walls (Miao *et al.*, 2006; Băetu & Ciongradi, 2011). We performed the nonlinear analyses of RC structural walls studied in this paper by using the SAP2000v14 software and the layered shell model existing in this code. Five layers have been defined, one corresponding to the confined and unconfined concrete in the wall and its boundaries and four corresponding to the reinforcement in the horizontal and vertical directions on both sides of the wall section (Fig. 4) (Sap2000 V14 Help).

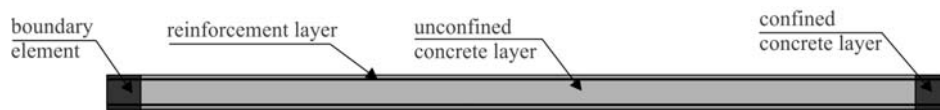

Fig. 4 – Layered shell element for structural walls analysis.

2.3. Finite Element Analysis in ANSYS 12 of the Short Connection

The definition of the structural model for short connections under cyclic loading can be developed in the following steps:

- a) Definition of a monotonic curve – the cyclic envelope can be coincident with the monotonic one.
- b) Definition of the unloading rules – the unloading branch can be linear.
- c) Definition of the re-loading rules – the re-loading branch may follow complex rules considering slip and pinching.

A monotonic curve for the short connection can be defined experimentally or by using the finite element method. The last possibility was selected in this case by using the computer program ANSYS 12 because it can simulate reinforced concrete elements with a very good accuracy, the results being close to the experimental ones (Kheyroddin & Naderpour, 2008; Raongjant & Jing, 2008).

The seismic nonlinear analysis of the reinforced concrete slit wall with short connections requires their hysteretic behaviour based on an adequate constitutive hysteretic model. The short connections have been introduced in SAP2000 as link elements with multi-linear pivot hysteretic plasticity property (Fig. 5) (Lepage *et al.*, 2006) because this hysteretic model is suitable for reinforced concrete members dominated shear. This model, which is capable to simulate very easy the pinching effect, is similar to the multi-linear constitutive model of Takeda but has additional parameters which control the degradation of the hysteretic behaviour. In this model the loading and reloading are directed to specific points named *pivot points* (Sap2000 V14 Help). The hysteretic force–displacement curve with stiffness and strength degradation and pinching effect was defined in Fig. 6 (Kwan *et al.*, 1999).



Fig. 5 – Slit wall analysed in SAP2000.

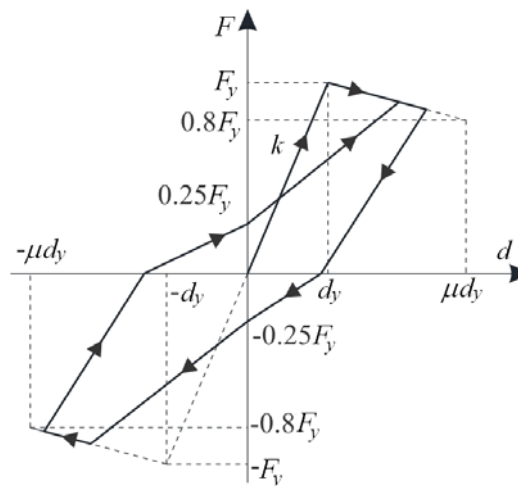

Fig. 6 – Hysteretic model for a RC short beam.

The construction of this hysteretic curve begins with the monotonic force–displacement curve of a short connection (Fig. 7), obtained with the finite element code ANSYS 12 and by using the pivot hysteretic rules for loading and unloading explained in the previous two paragraphs. The hysteretic parameters required are extracted from the experimental static (Fig. 8) and from cyclic analyses for short beams dominated by shear (Kwan *et al.*, 1999; Gedik *et al.*, 2011; Zhao *et al.*, 2004).

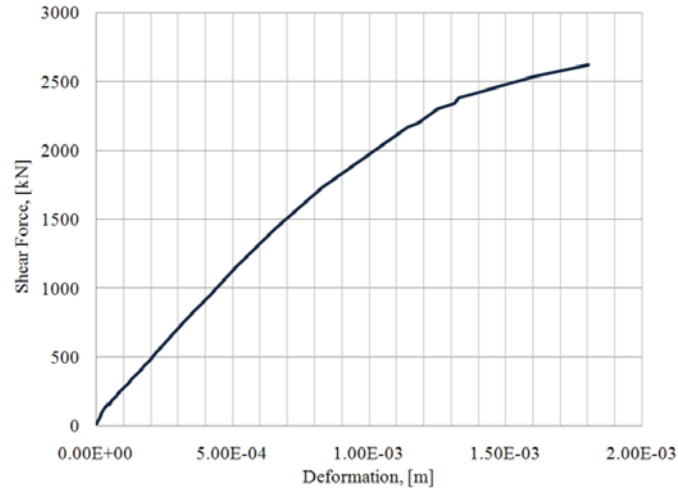

Fig. 7 – Monotonic force–displacement curve of the short connection with height of 40 m.

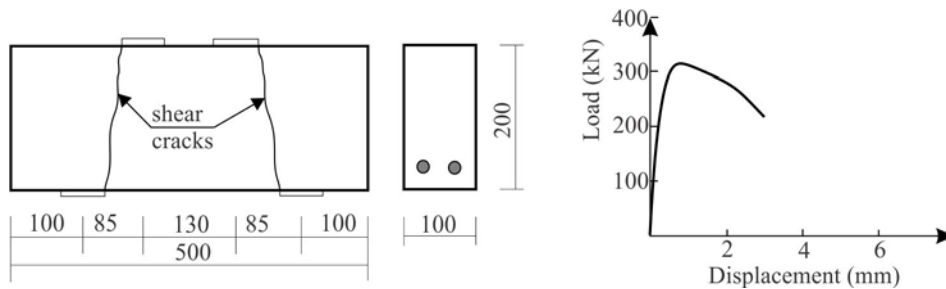

Fig. 8 – Static experimental analysis for a short beam.

2.4. Description of the Damage Index of Park&Ang

Numerous damage indices have been proposed in the literature, based on various conceptual frameworks. The damage index of Park & Ang, (1985), is nowadays widely used in seismic damage evaluation because of its simplicity and stability. This damage model served as a baseline for many researchers and was calibrated on the basis of structural degradations observed in experimental test of buildings. The damage index is calculated with the following relation

$$DI_{P\&A} = \frac{\delta_m}{\delta_u} + \frac{\beta}{\delta_u P_y} \int dE_h, \quad (1)$$

where: δ_m is the maximum deformation of the wall under seismic loading, δ_u – the ultimate deformation of the wall under monotonic static loading, P_y – the yield strength from the idealized curve, $\int dE_h$ – the incremental hysteretic energy dissipated during the seismic loading, β – the constant parameter of the model (usually, it has a value of 0.1).

The damage model of Park & Ang (Ghosh *et al.*, 2011; Belarbi & Prakash, 2009; Ladinovic *et al.*, 2011; Vera, 2006; Dorvaj & Eezadpanah, 2011; Ganjavi *et al.*, 2007; Vielma *et al.*, 2008, 2009, 2010; Valles *et al.*, 1996; Park & Ang, 1985) takes into account the degradation due to maximum incursion in the inelastic range and also the degradation due to cyclic deformations. The direct application of the damage model to a structural element, a story or a building, requires determining the ultimate deformations of the corresponding element, story or building. A building or a structural element reaches collapse when the damage index is more than 1 and the damages are repairable when the damage index is less than 0.4.

2.5. The Idealized Parameters of the Strength Envelope

In order to calculate two of the parameters needed in the estimation of the damage index, the ultimate displacement and the yielding force of the proposed structural slit wall, a cyclic analysis has been done. This type of analysis has been chosen because the monotonic static analysis does not provide good results in the case of slit walls. We decided to capture the strength degradation by performing a cyclic analysis with the computer program ANSYS 12 (Băetu & Ciongradi, 2012). We need herein only the strength envelope (Figs. 10 and 11), in order to extract the yielding force, and the ultimate displacement, required to calculate the damage index of Park & Ang. They are obtained by replacing each strength envelope with an idealized curve. The case of slit walls is a special one because the strength envelope has strength degradation and the idealized curve has to be tri-linear and, therefore, it was developed according to FEMA 440 (FEMA 440). The sum of the areas enclosed between the curve and the idealized curve must be zero (Figs. 9 and 10).

The yielding force, the yielding displacement and the ultimate displacements are shown in Table 1.

Table 1
The Parameters Required to Calculate the Park & Ang Damage Index

Parameters	Slit wall	Solid wall
Yielding displacement, [cm]	10	17
Yielding force, [kN]	1,900	2,565
Ultimate displacement, [cm]	90	32.8

Two more parameters are needed to calculate the Park & Ang damage index, that is, the maximum deformation of the wall under seismic loading and the incremental hysteretic energy dissipated during the earthquake. These parameters are calculated by means of a seismic analysis performed in SAP2000 with layered model described above.

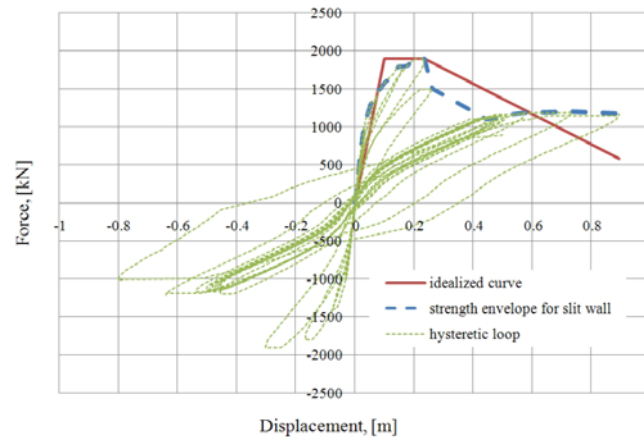

Fig. 9 – Strength envelope and idealized curve for the slit wall.

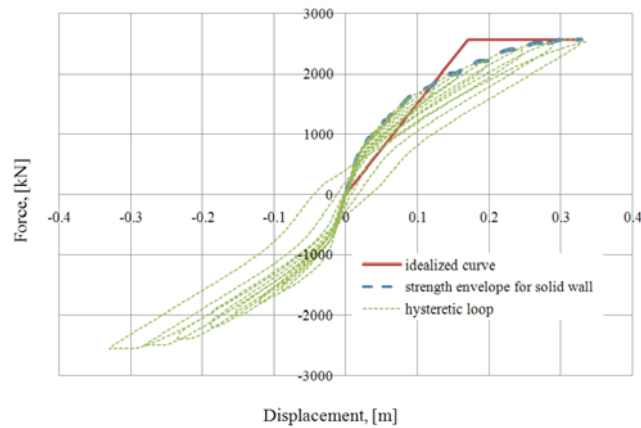

Fig. 10 – Strength envelope and idealized curve for the solid wall.

3. Seismic Analysis of a Dissipative Wall from a Multi-Storey Building

3.1. Description of the Studied Structure

The case study considers a multi-storey building in a seismic area from which a reinforced concrete structural wall is isolated (Fig. 11). The building is

located in the city of Iași, Romania, which has the following site characteristics: design ground acceleration $a_g = 0.2$ g, control period $T_c = 0.7$ s, ductility class H , importance factor $\gamma_I = 1$ (P100-1/2006). The building has dual reinforced concrete structure and regular form in plan and elevation. The seismic lateral loads applied upon the building are absorbed by the concrete core and, in the short direction, by the border walls. The fundamental period of the structure is $T_1 = 1.077$ s. The concrete used in the analysis is C32/40. The study is focused on a lateral wall with a length of 10 m. The thickness of the wall is 40 cm and is reinforced with vertical bars $\phi 14/15$ and horizontal bars $\phi 10/15$ and, at the boundary it has $8\phi 28$ bars (CR 2-1-1.1-2005, Băetu *et al.*, 2010). There are five connections along the wall height disposed at equal length of 12 m. The height of each connection is 0.40 m and the thickness of the slit is 5 cm.

3.2. Input Ground Motions for the Dynamic Analysis

For the dynamic analysis was chosen the Vrancea, Romania, 1977, N-S accelerogram (Fig. 12) (<http://www.incerc2004.ro/accelerogram.html>).

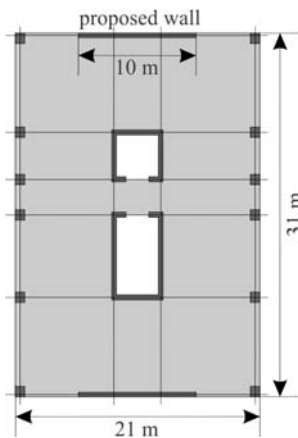

Fig. 11 – Dimensions of the studied building.

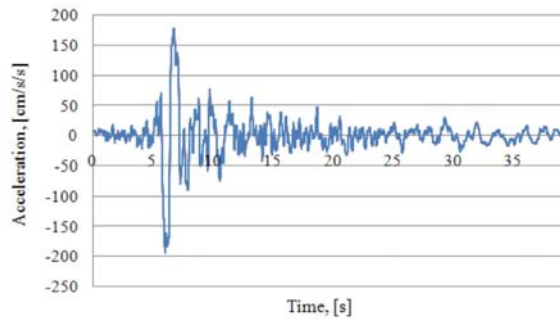

Fig. 12 – Vrancea, Romania, 1977, N-S component of the acceleration.

3.3. Comparative Analysis of the Slit and Solid Walls

The comparative hysteretic behaviour of the slit and solid walls as well as the dissipated hysteretic energies, obtained by performing their dynamic analysis with the seismic accelerogram of the Vrancea, 1977, N-S earthquake,

scaled at a peak ground acceleration (PGA) of 0.3 g, are shown in Figs. 13 and 14, respectively.

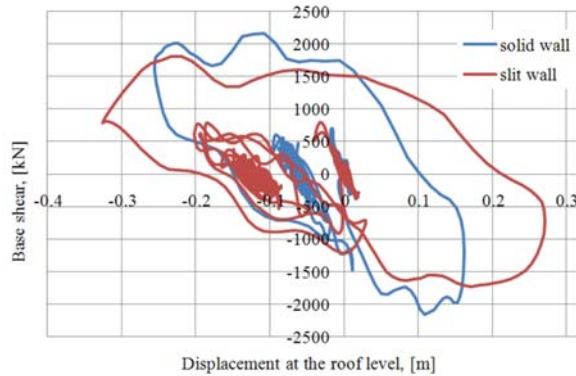

Fig. 13 – Hysteretic behaviour of the walls at Vrancea 1977 N-S earthquake, PGA = 0.3 g.

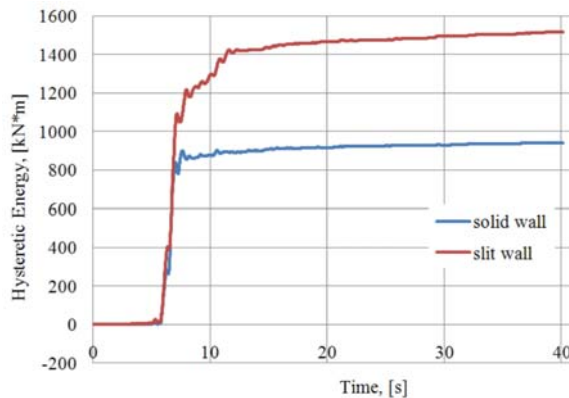

Fig. 14 – Hysteretic energy dissipation of the walls at Vrancea 1977 N-S earthquake, PGA = 0.3 g.

The comparison between the damage results obtained for the slit and the solid walls for both earthquakes considered in the analysis allows establishing a relationship between damage index (DI) and PGA (Fig. 15) and between the dissipated hysteretic energy and the displacement at the roof level (Figs. 16 and 17). The mentioned results are obtained by increasing the PGA and by scaling adequately the accelerograms for these PGA, until the collapse of the walls is reached. Two comparisons are made, one between the spectral accelerations (Fig. 18) and the other one between the displacement time-histories (Fig. 19), at the top of the studied walls subjected to the Vrancea, 1977, N-S component of the earthquake, scaled for a PGA of 0.4 g. It is important to note that for this PGA the short connections are crushed.

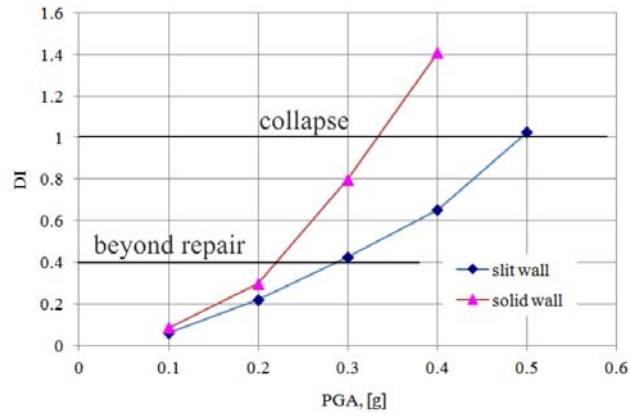

Fig. 15 – The variation of DI with PGA

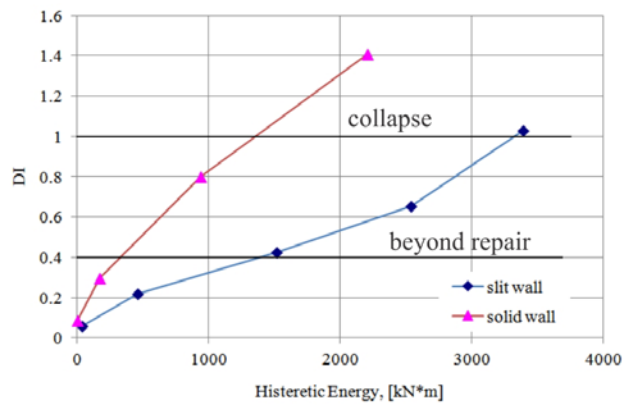

Fig. 16 – The variation of DI with hysteretic energy dissipated.

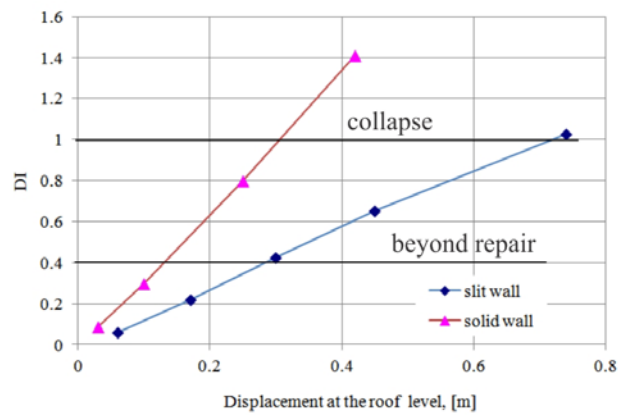

Fig. 17 – The variation of DI with displacement at the roof level.

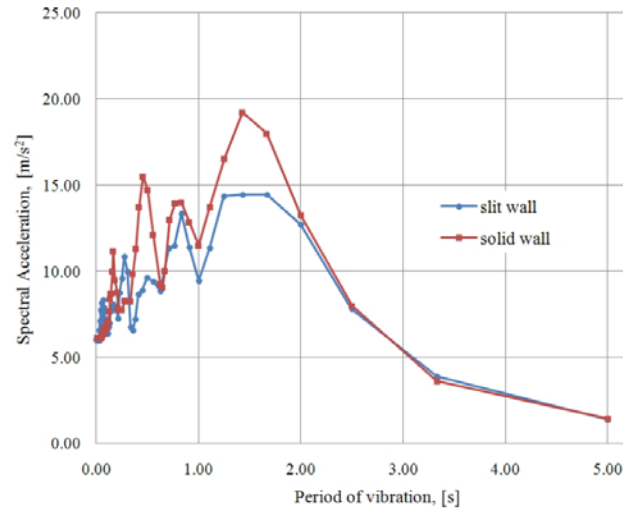

Fig. 18 – Spectral acceleration of the proposed walls for PGA = 0.4 g

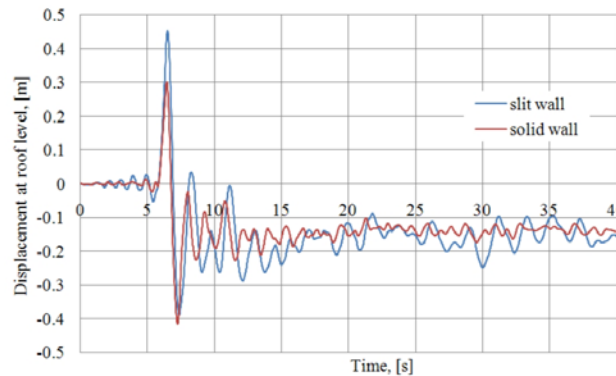

Fig. 19. The top displacement response of the proposed walls for PGA = 0.4 g.

4. Discussions of the Results

Performance levels describing the expected performance of the building in terms of damage level, economic losses and interruption of its functioning, can be defined, given a certain level of seismic hazard. Such performance levels, or limit states, are

a) *Life protection level* for a infrequent of rare seismic action, by preventing collapse of the structure or parts thereof and maintaining integrity and residual load capacity.

b) *Property loss reduction level* due to a frequent event, by limiting structural and non-structural damage.

The non-structural and structural damage limitation performance objective is achieved by limiting the overall deformations (lateral displacements) of the system to levels acceptable for integrity of all its parts. To achieve these performance levels, a structure should have a high stiffness for low intensity earthquakes and a low stiffness with high ductility for high intensity earthquakes. In agreement with the mentioned performance levels, the slit wall analysed in this study is an ideal element for designing buildings in seismic areas, because it has high initial stiffness and low final stiffness with high ductility.

The comparisons between the two proposed structural walls reveal that they have a quite different behaviour. From the results obtained for the Vrancea, 1977, N-S earthquake, we can see in Fig. 15, that the solid wall fails before the slit wall. The solid wall fails at a PGA of approx. 0.35 g and the slit wall fails at a PGA of approx. 0.5 g. Fig. 16 shows how much hysteretic energy is dissipated by the two walls until reaching the collapse level. It is clear that the slit wall is dissipating more hysteretic energy at every level of damage. Beyond the repair level, the slit wall dissipates approx. 1,500 kN.m hysteretic energy and the solid wall dissipates only approx. 400 kN.m hysteretic energy; at collapse level, the slit wall dissipates approx. 3,500 kN.m hysteretic energy and the solid wall dissipates only approx. 2,200 kN.m hysteretic energy. For a value of approx. 1,500 kN.m of dissipated hysteretic energy, the slit wall crosses the repair level and the solid wall collapses. This phenomenon occurs because the slit wall dissipates seismic energy by cracks extended along the whole surface of the wall and by the crush of the shear connections, while the solid wall dissipates seismic energy only by large cracks at the base of the wall. Normally, a great value of hysteretic energy indicates a high damage level but, in this case, although the slit walls have more cracks extended on almost the entire surface of the wall, these put not in risk the integrity of the wall. Even if the solid walls have fewer cracks, they are more dangerous, jeopardizing the structural system at small displacements.

When a short connection of the slit wall starts failing, the stiffness of the wall begins to decrease and the top displacement increases. This behaviour of the slit wall does not present a great problem because, as we can see in the Fig. 17, the damage index has low values. At the collapse level, the displacement of the slit wall is of approx. 0.7 m and for solid wall it is of approx. 0.3 m. It follows that, for the same displacement, the damage index is very different; for example, at a displacement of 0.3 m, the slit wall has a DI equal to 0.4 and it is beyond the repair level while the solid wall has a DI equal to 1 and it is at collapse level.

The nonlinear response of the reinforced concrete structural walls is accompanied by a decrease of stiffness and an increase of damping up to a certain level of damage. By increasing the damping, the effects of the ground

motion is reduced. After the failure of the short connections, the slit walls have a damping value greater than the solid wall. As we can see in Fig. 18, the spectral acceleration of the slit wall for the Vrancea 1977 N-S earthquake and for a $PGA = 0.4 \text{ g}$ has a lower values than that of the solid wall after the failure of the short connections. This means that the seismic forces are smaller for the slit wall and an economical design can be done. To capture the behaviour of the slit wall after the short connections fails, a PGA of 0.4 g was selected for the Vrancea 1977 N-S earthquake. Fig. 19 shows that the short connections fail after the fifth second of the seismic ground motion, once occurred the main shock and when the behaviour of the slit wall changes. The stiffness of the slit wall decreases and the natural period increases.

5. Conclusions

The aim of this study was to investigate the effectiveness of the slit walls solution in increasing the energy dissipation in reinforced concrete structural walls of high-rises buildings. In this paper, a slit zone is inserted along the height of the structural wall and five short connections are introduced in the slit. The proposed solution changes the behaviour of the solid wall providing more ductility, energy dissipation and a better crack pattern. When the short connections behave elastically, the initial stiffness of the slit wall is close to the stiffness of the solid wall but, when the short connections begin to develop large cracks or fail, the wall stiffness decreases rapidly, without developing large cracks at the base. Nonlinear dynamic analyses of the walls have been performed by using SAP2000 and a layered model, while the short connections were simulated with a hysteretic pivot model. The hysteretic force–displacement curve of the short connection is obtained using a series of hysteretic rules for loading and unloading. Using the dynamic analysis results, a damage evaluation of the walls was done by using the Park & Ang damage index.

Comparative studies between the slit and solid walls allow concluding that:

a) The nonlinear dynamic analyses prove that the solid wall fails before the slit wall, for both accelerograms considered in this study.

b) For the same displacement, the damage index, DI , is very different in the two cases; for example, at a displacement of 0.3 m the slit wall has a DI equal to 0.4 , value beyond the repair level, while the solid wall has a DI equal to 1 , corresponding to the collapse level.

c) The slit wall is dissipating more hysteretic energy than the solid wall; for example, when the slit wall is beyond the repair level, and dissipates approx. $1,500 \text{ kN.m}$ hysteretic energy, the solid wall collapses. This occurs because the slit wall has a better hysteretic energy dissipation capacity and dissipates

seismic energy by cracks extended on the entire surface of the wall and by crushing of the shear connections, while the solid wall dissipates seismic energy only by large cracks at the base of the wall.

The damping increases in the case of the slit wall after the failure of the short connections and the spectral acceleration is reduced, the seismic forces being thus also reduced, allowing this fact an economical design.

After the failure of the short connections, the slit wall stiffness decreases and the natural period increases, in this way being avoided the resonance phenomenon.

REFERENCES

- Băetu S., Ciongradi I., *Nonlinear Finite Element Analysis of Reinforced Concrete Slit Walls with ANSYS (II)*. Bul. Inst. Politehnic, Iași, **LVIII (LXII)**, 1, s. Constr. a. Archit., 99-111 (2012).
- Băetu S., Ciongradi I., *Nonlinear Analysis Models of The Reinforced Concrete Structural Walls*. Proc. of Internat. Conf. DEDUCON – Sust. Develop. in Civil Engng., Iași, **1**, 2011, A66-A83.
- Belmouden Y., Lestuzzi P., *Analytical Model for Predicting Nonlinear Reversed Cyclic Behaviour of Reinforced Concrete Structural Walls*. Engng. Struct., **29**, 1263-1276 (2007).
- Dorvaj M., Eezadpanah M., *Designing Reinforced Concrete Frames with Earthquake Damage Control*. J. of Amer. Sci., **7**, 8, 798-803 (2011).
- Gedik Y.H., Nakamura H., Ueda N., Kunieda M., *A New Stirrup Design Considering 3-D Effects in Short Deep Beams*. 12th East Asia-Pacific Conf. on Struct. Engng. a. Constr., Procedia Engng., **14**, 2964-2971 (2011).
- Ghosh S., Datta D., Katakdhond A.A., *Estimation of the Park-Ang Damage Index for Planar Multi-Storey Frames Using Equivalent Single-Degree Systems*. Engng. Struct., **33**, 2509-2524 (2011).
- Kachlakev D., Miller T., Yim S., *Finite Element Modelling of Reinforced Concrete Structures Strengthened with FRP Laminates*. Final Rep. SPR 316, Oregon Dept. of Transp., 2001.
- Kheyroddin A., Naderpour H., *Nonlinear Finite Element Analysis of Composite RC Shear Walls*. Iran. J. of Sci. & Technol., **32**, B2, 79-89 (2008).
- Kwak H.G., Kim D.Y., *Cracking Behaviour of RC Shear Walls Subject to Cyclic Loadings*. Comp. a. Concr., **1**, 1, 77-98 (2004).
- Kwan A.K.H., Dai H., Cheung Y.K., *Non-Linear Sesimic Responce of Reinforced Concrete Slit Shear Walls*. J. of Sound a. Vibr., **226**, 4, 701-718 (1999).
- Ladinovic D., Radujkovic A., Raseta A., *Seismic Performance Assessment Based on Damage of Structures. Part 1: Theory*. Archit. a. Civil Engng., **9**, 1, 77-88 (2011).
- Lepage A., Neuman S.L., Dragovich J.J., *Practical Modelling for Nonlinear Seismic Response of RC Wall Structures*. 8th Nation. Conf. on Earthquake Engng., San Francisco, California, April 18-22, 2006.

- Miao Z.W., Lu X.Z., Jiang J.J., Ze L.P., *Nonlinear FE Model for RC Shear Walls Based on Multi-Layer Shell Element and Microplane Constitutive Model*. Springer Berlin, Heidelberg, Comput. Methods in Engng. a. Sci., Hainan, China (2006).
- Nagarajan P., Jayadeep U.B., Pillai T.M.M., *Application of Micro Truss and Strut – and – Tie Model for Analysis and Design of RC Structural Elements*. Songklankarin J. of Sci. a. Technol., **31**, 6, 647-653 (2009).
- Park Y.J., Ang A.H.S., *Seismic Damage Analysis of Reinforced Concrete Buildings*. J. of Struct. Engng., **111**, 4, 740-757 (1985).
- Raongjant W., Jing M., *Finite Element Analysis on Lightweight Reinforced Concrete Shear Walls with Different Web Reinforcement*. The Sixth PSU Engng. Conf., Songkhla, Thailand, 2008, 61-67.
- Sharifi A., Banan M.R., *A Strain-Consistent Approach for Determination of Bonds of Ductility Damage Index for Different Performance Levels for Seismic Design of RC Frame Members*. Engng. Struct., **37**, 143-151 (2012).
- Vielma J.C., Bărbat A.H., Oller S., *An Objective Seismic Damage Index for the Evaluation of the Performance of RC Buildings*. The 14th World Conf. on Earthquake Engng., Beijing, China (2008).
- Vielma J.C., Bărbat A.H., Oller S., *Seismic Performance of Waffled-Slabs Floor Buildings*. Struct. a. Build. (Proc. of the Inst. of Civil Engng.), **162**, SB3,169-182 (2009).
- Vielma J.C., Bărbat A.H., Oller S., *Seismic Safety of Limited Ductility Buildings*. Bull. of Earthquake Engng., **8**, 1, 135-155 (2010).
- Zhao Z.Z., Kwan A.K.H., He X.G., *Nonlinear Finite Element Analysis of Deep Reinforced Concrete Coupling Beams*. Engng. Struct., **26**, 13-25 (2004).
- * * * *Code for Seismic Design of Buildings* (in Romanian). P100-1/2006.
- * * * *Code for the Design of Buildings with Reinforced Concrete Structural Walls* (in Romanian). CR 2-1-1.1-2005.
- * * * *Design of the Reinforced Concrete Structures* (in Romanian). SR EN 1992-1-1:2004. <http://www.incerc2004.ro/accelerogram.htm>.
- * * * Sap2000 V14 Help, Computers and Structures Inc., Berkeley, California, USA, 2009.

EVALUAREA DEGRADĂRII SEISMICE A PEREȚILOR DIN BETON ARMAT DISIPATORI DE ENERGIE

(Rezumat)

O proiectare economică a clădirilor bazată pe un criteriu de performanță ia în considerare disiparea de energie seismică acumulată în structură. În cazul unui perete structural zvelt, articulațiile plastice se dezvoltă doar la baza peretelui iar restul peretelui rămâne nedegradat. O soluție pentru a crește performanțele seismice ale unui perete structural din beton armat este de a crea o zonă șlițată cu conexiuni scurte. Degradarea acestor conexiuni scurte crește disiparea de energie. Obiectivul acestei soluții este de a crea o structură îmbunătățită pentru clădirile înalte multietajate care au o comportare

rigidă la acțiuni seismice de intensitate redusă și au o comportare ductilă la acțiunea unor acțiuni seismice de intensitate mare.

Se efectuează o analiză dinamică neliniară comparativă între pereți șlițați și pereți neșlițați, cu ajutorul programului de calcul SAP2000 folosind modelul cu straturi. Obiectivul principal este de a evalua degradarea pereților șlițați în comparație cu cei neșlițați.